



# BIKE-PACK SYSTEM™

Thank you for purchasing our VENTURA BIKE-PACK SYSTEM.  
Before use please read all instructions and our Limited Warranty carefully.

## To Fit : Suzuki GSX 1400 K2-K4 (02-04)

**S090/B** L-Brackets.

**PF14/B** Pack-Rack. For use with 'Aerodynamic' system packs.

**SR14/B** Sport-Rack.

**GH14/16/B** Grab-Handle

A range of various style packs, for the 'Aerodynamic' systems, along with storm covers and optional shoulder straps (where applicable) are available.

Check with your local dealer, distributor or contact us direct for the latest models.

### FITTING KIT CONTENTS

LD001/B locking device (fitted to L-Brackets)

- 1 LK001/S Key
- 2 Part # 42 57mm tube spacers
- 2 M8 x 35 Allenhead bolts (black zp)
- 2 M8 x 100 Allenhead bolts (black zp)
- 4 M8 x 17.0 x 1.4 flat washers (black zp)
- 4 M8 Nyloc nuts (black zp)

### FITTING INSTRUCTIONS

- 1 Remove seat and grabhandle.
- 2 Remove rear body (disconnect the seat release cable and tail light wiring plug).
- 3 Remove the rear inner mudguard mounting bolts. Lower the mudguard slightly and remove the fold out tie down hoops.
- 4 Fit the M8 x 100 bolts supplied down through the tie down hoop mounting hole and place a 57mm tube spacer over the bolt. Raise the rear mudguard and replace the mounting bolts.

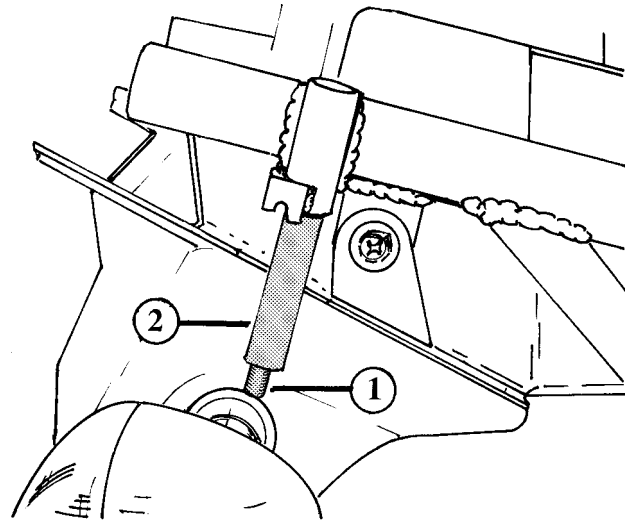
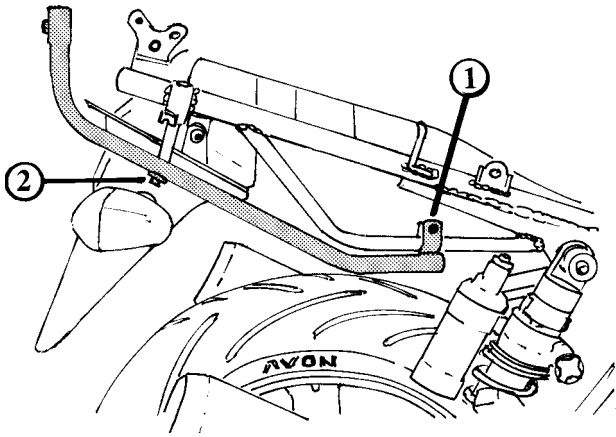

Diagram 1

- Legend to**
- |   |                          |
|---|--------------------------|
| 1 | M8 x 100 Allenhead bolts |
| 2 | 57mm tube spacer         |

Diagram 1:

- 5 Replace the body, re-engage the seat release cable and tail light connector. Leave the body loosely in place (No mounting bolts fitted).
- 6 The L-Bracket front 'U' mountings fit over the grab/lift rails, securing with the M8 x 35 Allenhead bolts with flat washers and nyloc nuts provided. Leave loose.  
  
The rear mounting fits up over the bolt and tube spacer previously fitted, secure with M8 flat washers and nuts provided.
- 7 Fit Pack-Rack or Sport-Rack into the L-Brackets and tighten the mounting bolts. (The use of a ball-head Allen key will make the tightening of the rear bolts easier).
- 8 Refit rear body mounting bolts and body pins, and grab handle.
- 9 Tighten the L-Bracket locking devices by following the procedure in the General Instructions For Use.



**Diagram 2**

**Legend to**            1        M8 x 35 bolt, flat washer and nut  
**Diagram 2:**         2        M8 flat washer and nut

**NOTE:** Cover upper surface of the grab handle with abrasion resistant film to prevent marking or damage to the surface finish.

**GENERAL INSTRUCTIONS FOR USE**



**The following instructions should be strictly adhered to. Failure to do so may result in an accident causing injury or death.**

**Locking Device Tightening Instruction**

**For racks with formed indents on swaged ends.**

- 1        Ensure the knurled locking nut is wound fully back and is in contact with the head of the locking device.
- 2        Tighten the locking device firmly and securely by hand making sure that it is centrally located in the indented groove on the swaged legs of the rack.
- 3        Turning the knurled locknut clockwise, tighten firmly by hand. Using the key tighten an extra 2mm ( $\frac{1}{8}$ " approx) of circumference travel.

**For racks without indents**

- 1        Ensure the knurled locking nut is wound fully back and is in contact with the head of the locking device.
- 2        Tighten the locking device by hand until it comes into positive and firm contact with the rack.
- 3        Using the key, tighten a further 1.125 ( $1\frac{1}{8}$ ) turns.
- 4        Turning the knurled locknut clockwise, tighten firmly by hand. Using the key tighten an extra 2mm ( $\frac{1}{8}$ " approx) of circumference travel.

**BEFORE USE**

All fasteners and components must be checked for tightness and security before each ride.

**RECOMMENDATION**

Any surfaces that could possibly come in contact with the pack(s) should be covered with protective material such as abrasion resistant film, to prevent marking or damage to the surface finish.

**RIDING SOLO**

When riding solo always have the pack facing forward with the load over the pillion seat.

**RIDING WITH A PILLION PASSENGER**

When riding with a pillion passenger the pack must be fitted facing rearwards.

**WARNING -**

The VENTURA Bike-Pack System was not designed as a back rest and should not be used as one by the pillion passenger.

**SECURING PACK TO PACK-RACK**

To secure the pack use the straps with the quick release clips and attach around the horizontal rung on the Pack-Rack carrier. On some models the quick release system is not available. In this situation loop the shoulder straps around the rung and fasten to the buckle.

**PACKING THE PACK**

Always place heavy items at the bottom of the pack and load evenly. Do not position sharp objects against the fabric of the pack.

**MAXIMUM CARRYING CAPACITY**

Unless specified to the contrary in the fitting instructions or the motorcycle manufacturers recommendations/specifications the recommended maximum load capacity of this system is 9kg (20lbs). It is important that the pack is always securely fastened to the Pack-Rack.

**MAXIMUM SPEED**

The maximum recommended speed that this system can be used is 130 kph (80mph) or the legal speed limit, whichever is the lower. This limit may be reduced by other accessories, worn tyres, improper handling, overall motorcycle condition or weather conditions.

**REMEMBER**

Exceeding the weight capacity or the recommended maximum speed may drastically affect the motorcycles handling, stability and performance.

**L-BRACKETS**

The L-Brackets must always have the Pack-Rack, Sport-Rack or Grab-Handle fitted.

**IMPORTANT**

The **VENTURA BIKE-PACK SYSTEM** is designed as a complete unit. The use of non **VENTURA** parts, bags or other attachments will render the warranty void.

**VENTURA** Light Guard:        VP073

**"Happy and Safe Motorcycling"**

## LIMITED WARRANTY

**NOTE: Some jurisdictions do not allow limitations on how long an implied warranty, if any, lasts, and do not allow the exclusion of limitation of incidental or consequential damages so the limitations and exclusions below may not apply to you. This warranty gives specific legal rights, you may have other rights which vary from jurisdiction to jurisdiction**

Dold Industries Limited ("Dold") warrants this product to be free from defects in materials and workmanship under normal use and maintenance for a period of one year from its date of original purchase. Dold shall, at its option, either repair or replace a defective product returned to it or its authorised agents, freight prepaid.

**This warranty does not apply to any product which has been altered, damaged or rendered non-functional through improper installation or maintenance, abnormal wear and tear due to exposure to the elements, negligence, abuse, accidents or any like circumstance.**

**Dold shall not be liable for any incidental nor consequential loss or damage resulting directly or indirectly from any defective product, its sole obligation being to repair or replace such defective product.**

This warranty is in lieu of, and excludes, all other warranties, expressed or implied, including the warranties of merchantability and of fitness for a particular purpose.

To make a warranty claim return the product to the dealer who supplied it with evidence of date of purchase. If you are not satisfied with their response, please contact the distributors for your country or: Dold Industries Ltd, 17 Perclo Place, P O Box 10-393, Te Rapa, Hamilton, New Zealand. Telephone +64 (7) 849-4392. Facsimile +64 (7) 849-4114. E-mail: [dold@ventura-bike.com](mailto:dold@ventura-bike.com) Internet: [www.ventura-bike.com](http://www.ventura-bike.com)

E & O E