



BIKE-PACK SYSTEM™

Thank you for purchasing our VENTURA BIKE-PACK SYSTEM.
Before use please read all instructions and our Limited Warranty carefully.

To Fit :
Triumph Daytona: 750, 1000
Trophy: 900, 1200
Trophy: 900, 1200 (1993)
Trophy: 900, 1200 (1994)

T008/B L-Brackets.
PF17/B Pack-Rack. For use with 'Aerodynamic' system packs.
SR17/B Sport-Rack.
GH15/17/B Grab-Handle.

A range of various style packs for the 'Aerodynamic' systems, along with storm covers and optional shoulder straps (where applicable) are available.

Check with your local dealer, distributor or contact us direct for the latest models.

FITTING KIT CONTENTS

LD001/B locking device (fitted to L-Brackets)

- 1 LK001/S Key
- 1 M8 x 40 bolt (black or bright zp)
- 1 25mm tube spacer (black or bright zp)
- 2 9mm tube spacers (black or bright zp)
- 2 M8 x 30 bolts (black or bright zp)
- 2 M8 x 60 bolts (black zp)
- 2 M8 spring washers (black or bright zp)
- 2 M8 nuts (black or bright zp)
- 2 #107 brackets (black zp)
- 7 M8 x 17 x 1.4 flat washers (black zp)

FITTING INSTRUCTIONS

TRIUMPH TROPHY 900, 1200, (1994)

- 1 Remove seat, grab rail, and side covers.
- 2 Remove the indicator mounting bolts and discard. Allow the indicator mounting brackets to hang downwards on the wiring. At these points on the frame mount the #107 brackets with the threaded end downwards and outwards, using the M8 x 30 bolts with a 9mm tube spacer and two M8 flat washers between the bracket and the frame. Leave loose.
- 3 Bolt the rear L-Bracket mounting to the base of the hanging #107 bracket using the M8 x 60 bolts and a flat washer. Leave loose.
- 4 On the left hand side, remove the rear lift rail to frame bolt. The front L-Bracket mount fits outside at this point, using the original bolt. Leave loose.

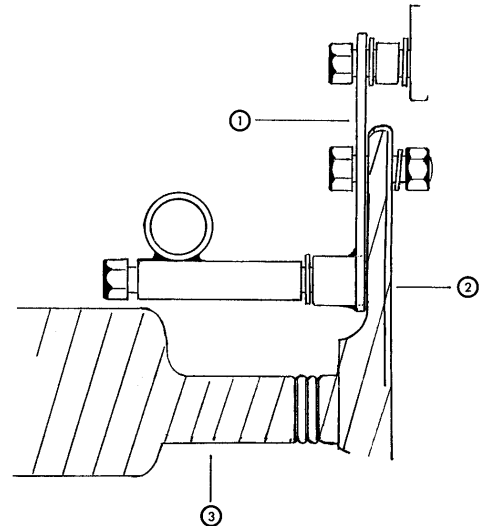

Diagram 1

Legend to	1	Part #107 bracket
Diagram 1	2	Indicator mounting bracket
	3	Indicator

- 5 On the right hand side, opposite the left hand mounting fit the 25mm tube spacer between the L-Bracket mounting and the frame and secure with the M8 x 40 bolt and flat washer provided. Leave loose.
- 6 Fit the indicator mounting brackets inside the #107 brackets and secure with the M8 x 16 bolts with a spring washer and nut on the inside.
- 7 Fit Pack-Rack or Sport-Rack into the L-Brackets, ensure the rack is level and tighten all mounting bolts. Remove the Pack-Rack or Sport Rack.
- 8 Refit the side covers, grab rail and seat.
- 9 Fit Pack-Rack or Sport-Rack into the L-Brackets. Tighten the L-Bracket locking devices by following the procedure in the General Instructions For Use.

TRIUMPH TROPHY 900, 1200 (1993)

- 1 Remove seat, grab rail, rear body and side covers.
- 2 Remove frame indicator mounting bolts and discard. At these points mount the #107 brackets with the threaded end downwards and outwards, using the M8 x 30 bolts with a 9mm tube spacer and one flat washer between the bracket and the indicator mount. Leave loose.
- 3 Bolt the rear L-Bracket mounting to the hanging #107 brackets using the M8 x 60 bolts and a flat washer.
- 4 On the left hand side, remove the rear lift rail to frame bolt. The front L-Bracket mount fits outside at this point reusing the original bolt.
- 5 On the right hand side, opposite the left hand mounting, fit the 25mm tube spacer between the L-Bracket mounting and the frame and secure with the M8 x 40 bolt and M8 flat washer supplied.
- 6 Tighten all bolts.
- 7 Refit side covers, rear body, grab rail and seat.
- 8 Fit Pack-Rack or Sport-Rack into the L-Brackets. Tighten the L-Bracket locking devices by following the procedure in the General Instructions For Use.

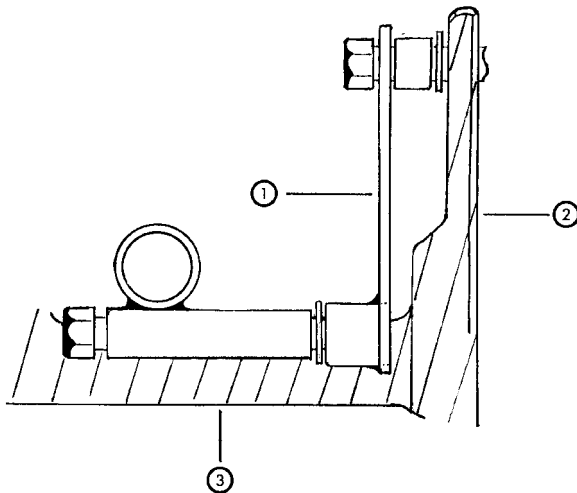
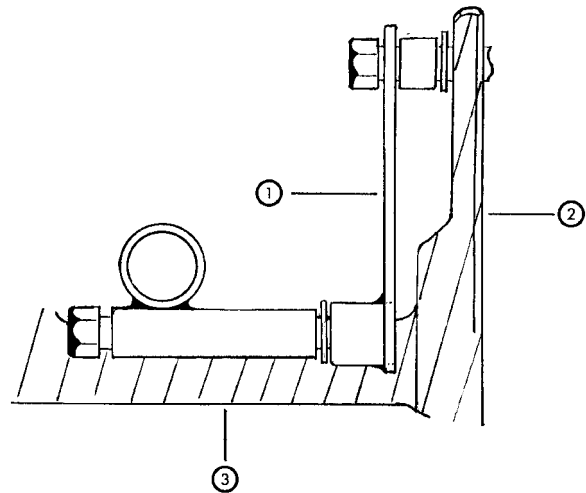

Diagram 2

Legend for Diagram 2	1	Part #107 bracket
	2	Indicator mounting bracket
	3	Indicator

TRIUMPH TROPHY 900, 1200 & DAYTONA 750, 1000

- 1 Remove seat, grab rail, rear body and side covers.
- 2 Remove frame to indicator mounting bolts and discard. At these points mount the #107 brackets with the threaded end downwards and outwards, using the M8 x 30 bolts with a 9mm tube spacer and one flat washer between the bracket and the indicator mount. Leave loose.
- 3 Bolt the rear L-Bracket mounting to the hanging #107 brackets using the M8 x 60 bolts and a flat washer.
- 4 Where the exhaust support/lift rail bolts to the frame, remove the rear bolt. The front L-Bracket mount fits outside at this point reusing the original bolt.
- 5 Tighten all bolts.
- 6 Refit side covers, rear body, grab rail and seat.
- 7 Fit Pack-Rack or Sport-Rack into the L-Brackets, ensure the rack is level and tighten the mounting bolts. Tighten the L-Bracket locking devices by following the procedure in the General Instructions For Use.



GENERAL INSTRUCTIONS FOR USE



The following instructions should be strictly adhered to. Failure to do so may result in an accident causing injury or death.

Locking Device Tightening Instruction

For racks with formed indents on swaged ends.

- 1 Ensure the knurled locking nut is wound fully back and is in contact with the head of the locking device.
- 2 Tighten the locking device firmly and securely by hand making sure that it is centrally located in the indented groove on the swaged legs of the rack.
- 3 Turning the knurled locknut clockwise, tighten firmly by hand. Using the key tighten an extra 2mm ($\frac{1}{8}$ " approx) of circumference travel.

For racks without indents

- 1 Ensure the knurled locking nut is wound fully back and is in contact with the head of the locking device.
- 2 Tighten the locking device by hand until it comes into positive and firm contact with the rack.
- 3 Using the key, tighten a further 1.125 ($1\frac{1}{8}$) turns.
- 4 Turning the knurled locknut clockwise, tighten firmly by hand. Using the key tighten an extra 2mm ($\frac{1}{8}$ " approx) of circumference travel.

BEFORE USE

All fasteners and components must be checked for tightness and security before each ride.

RECOMMENDATION

Any surfaces that could possibly come in contact with the pack(s) should be covered with protective material such as abrasion resistant film, to prevent marking or damage to the surface finish.

RIDING SOLO

When riding solo always have the pack facing forward with the load over the pillion seat.

RIDING WITH A PILLION PASSENGER

When riding with a pillion passenger the pack must be fitted facing rearwards.

WARNING - The VENTURA Bike-Pack System was not designed as a back rest and should not be used as one by the pillion passenger.

SECURING PACK TO PACK-RACK

To secure the pack use the straps with the quick release clips and attach around the horizontal rung on the Pack-Rack carrier. On some models the quick release system is not available. In this situation loop the shoulder straps around the rung and fasten to the buckle.

PACKING THE PACK

Always place heavy items at the bottom of the pack and load evenly. Do not position sharp objects against the fabric of the pack.

MAXIMUM CARRYING CAPACITY

Unless specified to the contrary in the fitting instructions or the motorcycle manufacturers recommendations/specifications the recommended maximum load capacity of this system is 9kg (20lbs). It is important that the pack is always securely fastened to the Pack-Rack.

MAXIMUM SPEED

The maximum recommended speed that this system can be used is 130 kph (80mph) or the legal speed limit, whichever is the lower. This limit may be reduced by other accessories, worn tyres, improper handling, overall motorcycle condition or weather conditions.

REMEMBER

Exceeding the weight capacity or the recommended maximum speed may drastically affect the motorcycles handling, stability and performance.

L-BRACKETS

The L-Brackets must always have the Pack-Rack, Sport-Rack or Grab-Handle fitted.

IMPORTANT

The VENTURA BIKE-PACK SYSTEM is designed as a complete unit. The use of non VENTURA parts, bags or other attachments will render the warranty void.

The following VENTURA accessories are available for these model motorcycles:

VENTURA Light-Guards:

Daytona 750, 1000	VP021
Trophy 900, 1200	VP047
Trophy 900, 1200 (1993)	VP047
Trophy 900, 1200 (1994)	VP047

"Happy and Safe Motorcycling"

LIMITED WARRANTY

NOTE: Some jurisdictions do not allow limitations on how long an implied warranty, if any, lasts, and do not allow the exclusion of limitation of incidental or consequential damages so the limitations and exclusions below may not apply to you. This warranty gives specific legal rights, you may have other rights which vary from jurisdiction to jurisdiction.

Dold Industries Limited ("Dold") warrants this product to be free from defects in materials and workmanship under normal use and maintenance for a period of one year from its date of original purchase. Dold shall, at its option, either repair or replace a defective product returned to it or its authorised agents, freight prepaid.

This warranty does not apply to any product which has been altered, damaged or rendered non-functional through improper installation or maintenance, abnormal wear and tear due to exposure to the elements, negligence, abuse, accidents or any like circumstance.

Dold shall not be liable for any incidental nor consequential loss or damage resulting directly or indirectly from any defective product, its sole obligation being to repair or replace such defective product.

This warranty is in lieu of, and excludes, all other warranties, expressed or implied, including the warranties of merchantability and of fitness for a particular purpose.

To make a warranty claim return the product to the dealer who supplied it with evidence of date of purchase. If you are not satisfied with their response, please contact the distributors for your country or: Dold Industries Ltd, 17 Perclo Place, P O Box 10-393, Te Rapa, Hamilton, New Zealand. Telephone +64 (7) 849-4392. Facsimile +64 (7) 849-4114. E-mail: dold@ventura-bike.com Internet: www.ventura-bike.com

E & O E